

# DOUBLE-RAIL TYPE HOIST WITH MOTOR-DRIVEN TROLLEY

WIRE  
HOIST

Ordinary Hoist

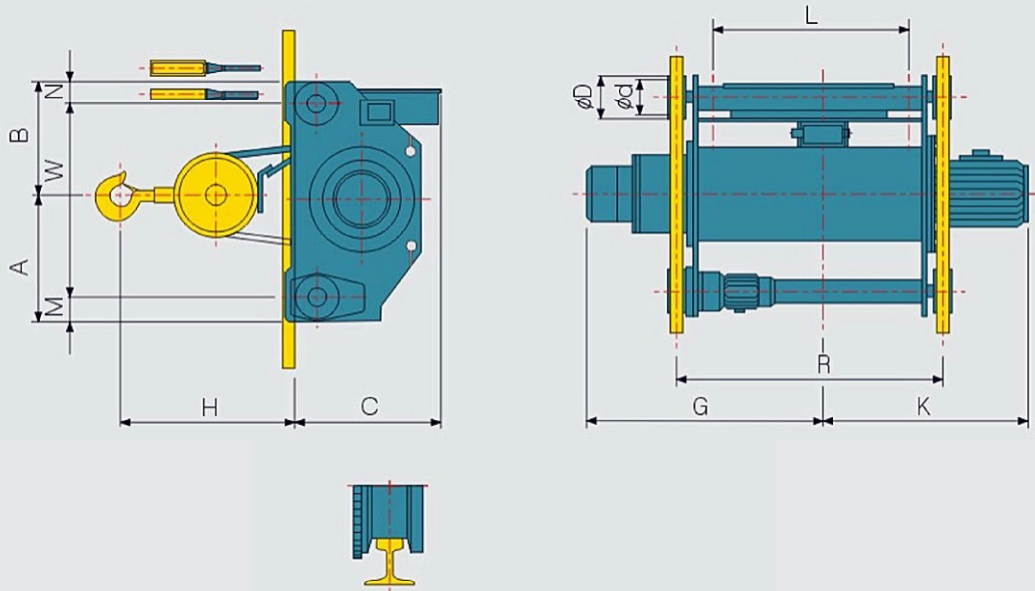

## Tables of Dimensions

Capacity (ton)		2	2.8	3	5	
Model		KDWD 2	KDWD 2.8	KDWD 3	KDWD 5	
Hoisting Lift (m)		12	12	12	12	
Hoisting	Speed(m/min)	High speed 50/60(Hz)	8.4/10	7.5/9	7.5/9	4.7/5.6
		Low speed 50/60(Hz)	4.2/5	3.7/4.5	3.7/4.5	3.5/4.2
	Motor(KwXP)	High speed	3.7 X 4	4.8 X 4	5.5 X 4	5.5 X 6
		Low speed	1.8 X 8	2.4 X 8	2.8 X 8	4.2 X 8
Brake		D.C Magnetic Disc Brake				
Traversing	Traversing Speed (m/min)	High speed 50/60(Hz)	20/24	20/24	20/24	20/24
		Low speed 50/60(Hz)	13/16	13/16	13/16	13/16
	Traversing Motor (KwXP)	High speed	0.75 X 4	0.75 X 4	0.75 X 4	0.75 X 4
		Low speed	0.5 X 6	0.5 X 6	0.5 X 6	0.5 X 6
Wire rope DIA(mm) No. Of Falls		8φ X 4	9φ X 4	9φ X 4	12.5φ X 4	
Approx. Dimensions(mm)	H	415	420	420	510	
	R	950	950	950	1150	
	A	465	465	465	510	
	B	390	390	390	470	
	C	530	550	550	590	
	G	740	785	785	945	
	K	705	705	705	845	
	W	650	650	650	760	
	L	680	690	690	890	
	M	120	120	120	120	
	N	95	95	95	105	
φd	140	140	140	165		
φD	170	170	170	195		
RAIL (kg/m)		15	15	15	15	
Approx.Weight(kg)		450	550	550	850	

[ 정밀수치를 요하는 연장은 당시에 사전 확인바랍니다. If minute dimension is required on the side. It should be informed to us in advance.

# DOUBLE-RAIL TYPE HOIST WITH MOTOR-DRIVEN TROLLEY

WIRE  
HOIST

Ordinary Hoist

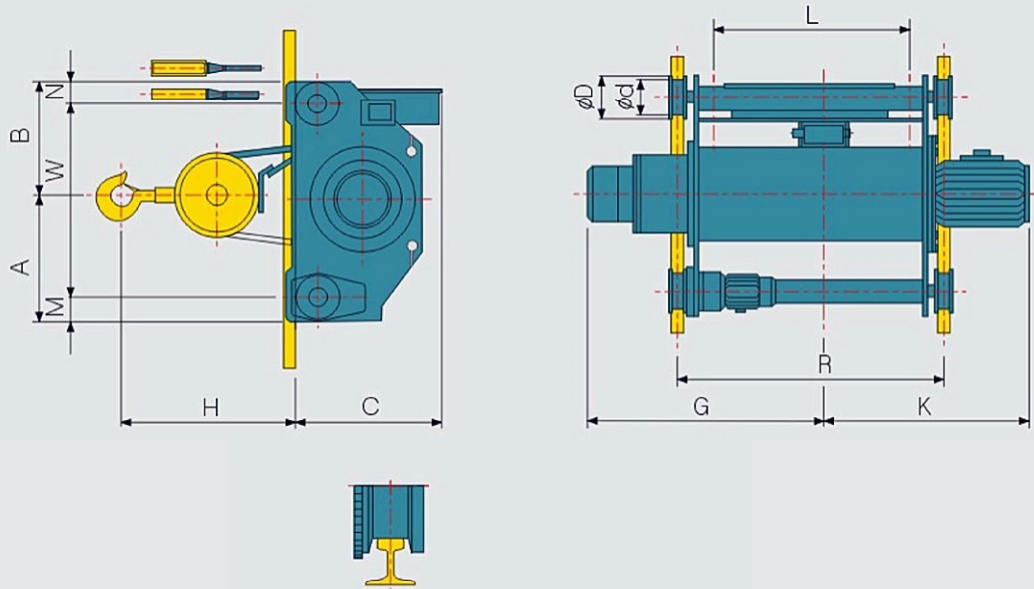

## Tables of Dimensions

Capacity (ton)		7.5	10	15	20	30	
Model		KDWD 7.5	KDWD 10	KDWD 15	KDWD 20	KFD 30	
Hoisting Lift (m)		12	12	12	12	12	
Hoisting	Speed(m/min)	High speed 50/60(Hz)	3.1/3.8	3.7/4.5	3.7/4.5	3.5/4.2	2.3/2.8
		Low speed 50/60(Hz)	2.3/2.8	2.5/3	2.5/3	2.3/2.8	1.5/1.8
	Motor(KwXP)	High speed	5.5 X 6	9 X 8	13 X 8	17 X 8	17 X 8
		Low speed	4.2 X 8	6 X 12	8.5 X 12	11.5 X 12	11.5 X 12
Brake		D.C Magnetic Disc Brake					
Traversing	Traversing Speed (m/min)	High speed 50/60(Hz)	12.5/15	12.5/15	12.5/15	12.5/15	12.5/15
		Low speed 50/60(Hz)	8.3/10	8.3/10	8.3/10	8.3/10	8.3/10
	Traversing Motor (KwXP)	High speed	0.75 X 4	0.75 X 4	1.5 X 4	1.5 X 4	1.5 X 4 (2 Units)
	Low speed	0.75 X 6	0.75 X 6	1.0 X 6	1.0 X 6	1.0 X 6 (2 Units)	
Wire rope DIA(mm) No. Of Falls		14φ X 4	16φ X 4	20φ X 4	22.4φ X 4	22.4φ X 4	
Approx. Dimensions(mm)	H	730	775	995	1175	1790	
	R	1150	1150	1200	1300	1800	
	A	525	565	625	670	940	
	B	480	510	555	615	940	
	C	550	670	850	870	935	
	G	935	975	1075	1165	1425	
	K	835	955	1005	1195	1455	
	W	800	865	920	1000	1540	
	L	850	850	870	935	1420	
	M	110	110	130	140	180	
	N	95	100	130	140	160	
	φd	165	165	180	220	250	
	φD	195	195	210	250	280	
RAIL (kg/m)		15	15	22	22	30	
Approx.Weight(kg)		900	1200	1850	2300	3450	

[ 정밀수치를 요하는 현장은 당사에 사전 확인바랍니다. If minute dimension is required on the side. It should be informed to us in advance.

09 <http://www.kdhoist.com>